

H-V/ VQ Series Low noise fixed displacement vane pumps

DOUBLE PUMPS

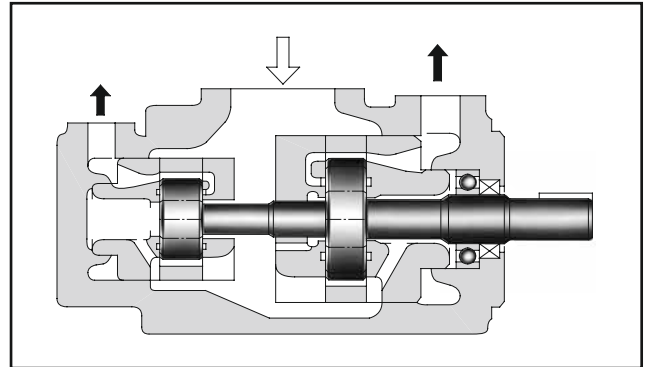
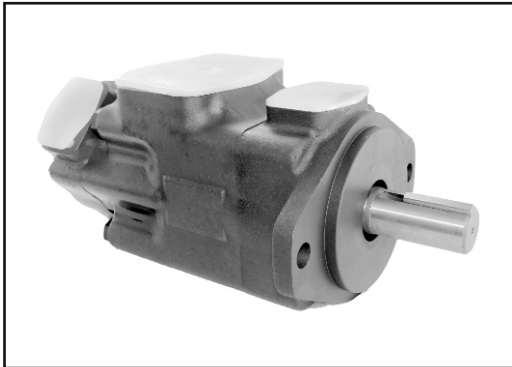

ORDERING CODE

H-2520V / VQ - 21 - A - 14 - 1 - CC - (LH) - 22

1 2 3 4 5 6 7 8 9

1 Low noise fixed displ. vane pump

- H-2520V / VQ Series
- H-3520V / VQ Series
- H-3525V / VQ Series
- H-4520V / VQ Series
- H-4525V / VQ Series
- H-4535V / VQ Series

2 Shaft end displacement code

Series	Displacement
H-25*V / VQ Series	10,12,14,15,17,19,21
H-35*V / VQ Series	21,25,30,32,35,38,45
H-45*V / VQ Series	42,45,50,57,60,66,75

3 Port Connections

"A" SAE 4Bolt Flange

4 Cover end displacement code

Series	Displacement
H-*20V / VQ Series	2,3,4,5,6,7,8,9,11,12,14
H-*25V / VQ Series	10,12,14,15,17,19,21
H-*35V / VQ Series	21,25,30,32,35,38,45

5 Shaft

- 1 parallel sq. key H-2520V / VQ
- 86 parallel sq. key H-3520V / VQ
- 11 splined H-3525V / VQ
- H-4520V / VQ
- H-4525V / VQ
- H-4535V / VQ

6 Shaft end pump (viewed from cover end)

- A: opposite inlet
- B: 90' CCW from inlet
- C: inline with inlet
- D: 90' CW from inlet

7 Cover end pump (viewed from cover end)

- A: 135' CCW from inlet
- B: 45' CCW from inlet
- C: 45' CW from inlet
- D: 135' CW from inlet

8 Rotation (viewed from shaft end)

- Omit for CW
- LH: CCW

9 Design no.

- 22 For V Series
- 20 For VQ Series

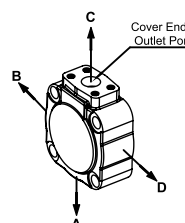
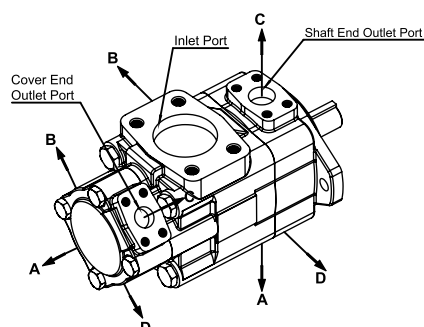

SHAFT TYPES

Splined Shafts

Dimensions in millimeters (inches)

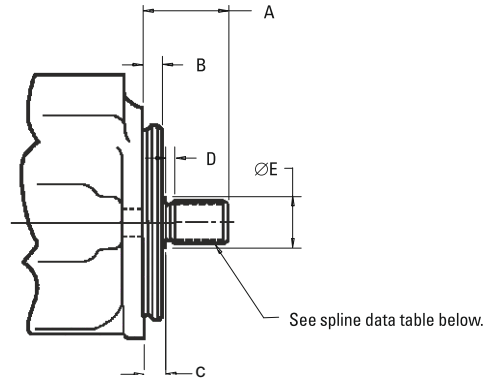

Pump	Shaft Code	A	B	C	D	ØE	Spline Data (See below.)
H-2520V / VQ	11	44,5 (1.75)	9,53 (.375)	11,1 (.437)	4,1 (.16)	27,8 (1.09)	A
H-3520V / VQ H-3525V / VQ	11	58,7 (2.31)	9,53 (.375)	11,1 (.437)	6,4 (.25)	35,1 (1.38)	D
H-4520V / VQ H-4525V / VQ H-4535V / VQ	11	61,9 (2.44)	12,7 (.500)	14,3 (.565)	9,7 (.38)	39,6 (1.56)	D

Spline Data Table (Involute splines from above chart)						
Spline Data Reference	Number of Teeth	Pitch	Major Diameter	Form Diameter	Minor Diameter	Minor Diameter
A	13	16/32	22,17 (.873) 22,15 (.872)	19,03 (.749)	18,16 (.715)	Major dia. fit
D	14	12/24	31,70 (1.248) 31,67 (1.247)	27,4 (1.08)	26,42 (1.040)	Major dia. fit

Straight Key Shafts

Dimensions in millimeters (inches)

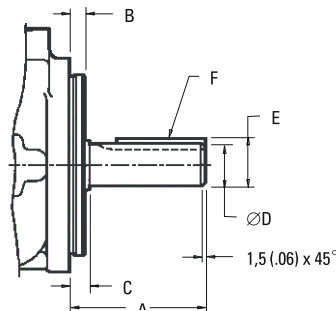

Pump	Shaft Code	A	B	C	ØD	E	F key width x length
H-2520V / VQ	1	58,7 (2.31)	9,53 (.375)	11,1 (.435)	22,23 (.875) 22,20 (.874)	24,5 (.966) 24,4 (.961)	4,75 (.187) x 32 (1.25)
	86	77,7 (3.06)	9,53 (.375)	11,1 (.435)	25,37 (.999) 25,35 (.998)	28,3 (1.11) 28,1 (1.10)	6,36 (.250) x 50,8 (2.00)
H-3520V / VQ H-3525V / VQ	1	73,2 (2.88)	9,53 (.375)	11,1 (.435)	31,75 (1.250) 31,70 (1.248)	35,36 (1.39) 34,10 (1.38)	7,94 (.313) x 38,1 (1.50)
	86	85,9 (3.38)	9,53 (.375)	11,1 (.435)	34,90 (1.374) 34,87 (1.373)	38,6 (1.52) 38,3 (1.51)	7,92 (.312) x 54 (2.13)
H-4520V / VQ H-4525V / VQ H-4535V / VQ	1	62,0 (2.44)	12,7 (.500)	14,22 (.560)	31,75 (1.250) 31,70 (1.248)	35,36 (1.39) 34,10 (1.38)	7,92 (.312) x 28,5 (1.12)
	86	87,4 (3.44)	12,7 (.500)	14,22 (.560)	38,07 (1.499) 38,05 (1.498)	42,4 (1.67) 42,1 (1.66)	9,53 (.375) x 50,8 (2.00)